

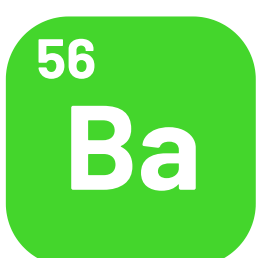

# MINIATURE ATOM SOURCE

## Available Elements

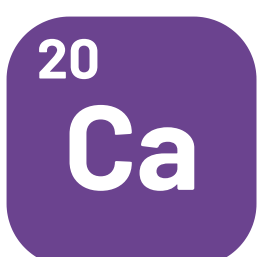

## PRODUCT DESCRIPTION

Ultra-low-power optically-heated atomic beam source for loading ion traps. Precision fused silica construction ensures high thermal efficiency, negligible outgassing and high degree of atomic beam collimation. Compatible with both 4K-cryogenic and room-temperature UHV environments.

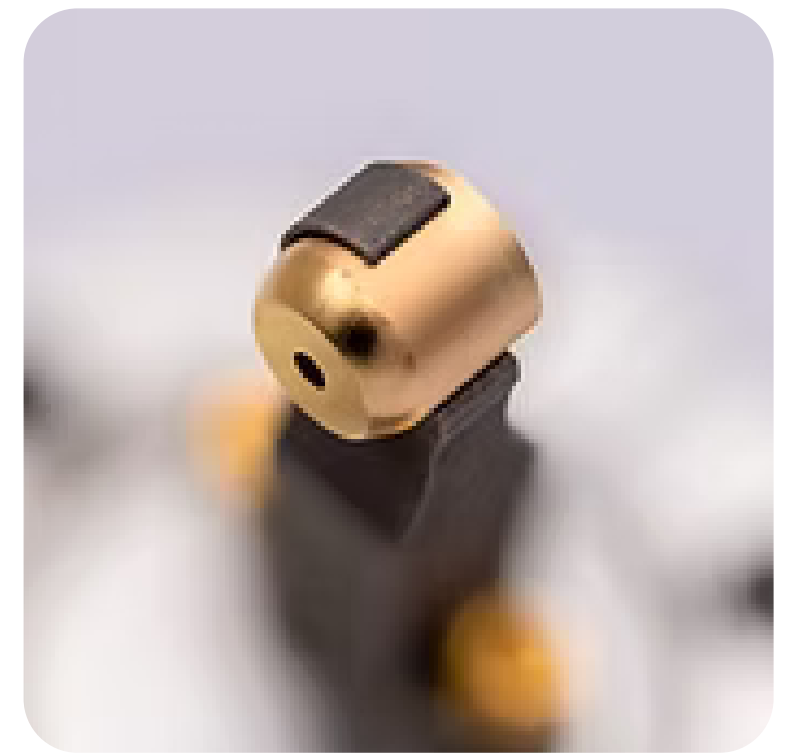

## TECHNICAL NOTES

- **ATOM BEAM DIVERGENCE:** Standard:  $3^\circ$  full-angle divergence, customisation on request
- **HEATING LASER:** Continuous-wave, broadband compatibility,  $>500$  nm recommended
- **SOURCE LIFETIME:**  $>10$  years continuous operation at typical operating parameters
- **SHELF STORAGE:** Multi-year shelf life sealed in inert atmosphere hermetic packaging

## PERFORMANCE CHARACTERISTICS

The following specifications are calculated for  $3^\circ$  full-angle divergence at room-temperature.

### Atom number density

Contours show peak atom number density in atoms/cm<sup>3</sup> for varying input power and operating distance. The recommended atom number density for ion trap loading is  $10^2$  atoms/cm<sup>3</sup>.

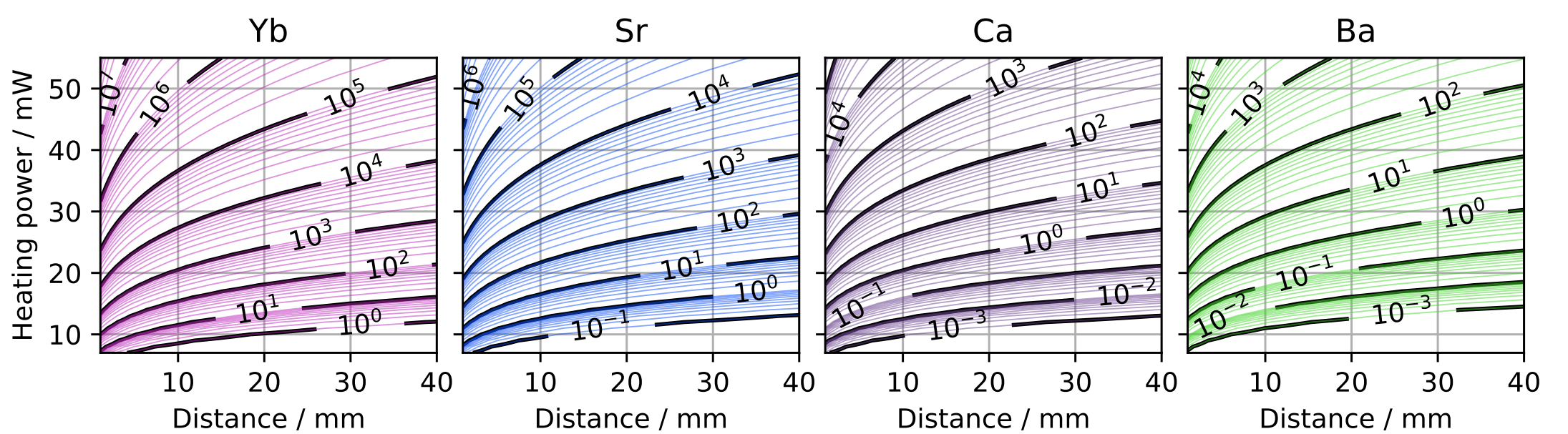

### Atom flux & kinetic energy

The total number of atoms emerging from the source per second is shown for different heating powers. The mean of the kinetic energy distribution of the collimated atomic beam is shown on the top axis. For ion trap loading, mean kinetic energies range from 60 meV to 80 meV.

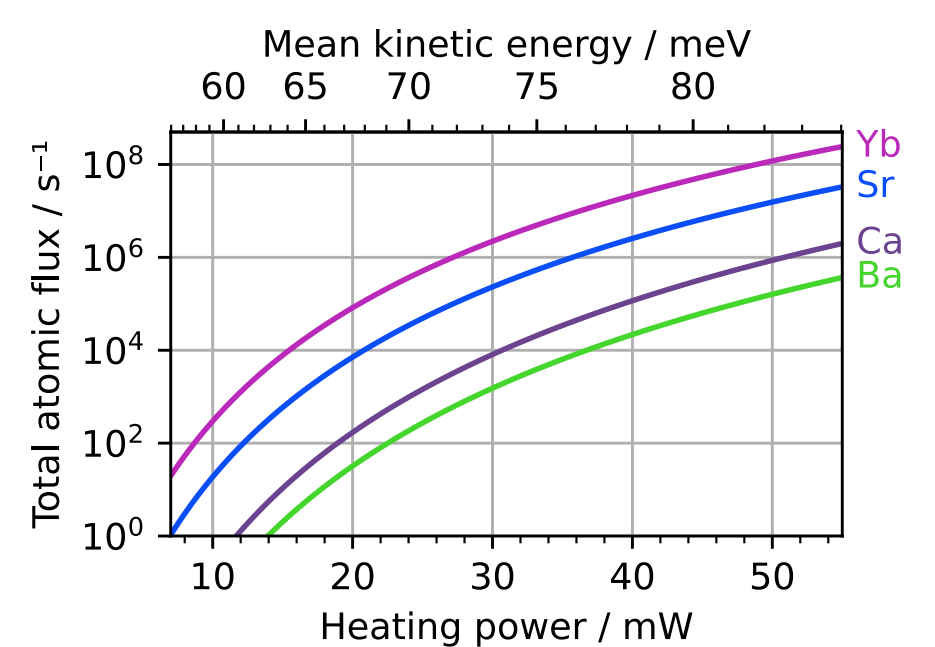

## MECHANICAL DRAWING

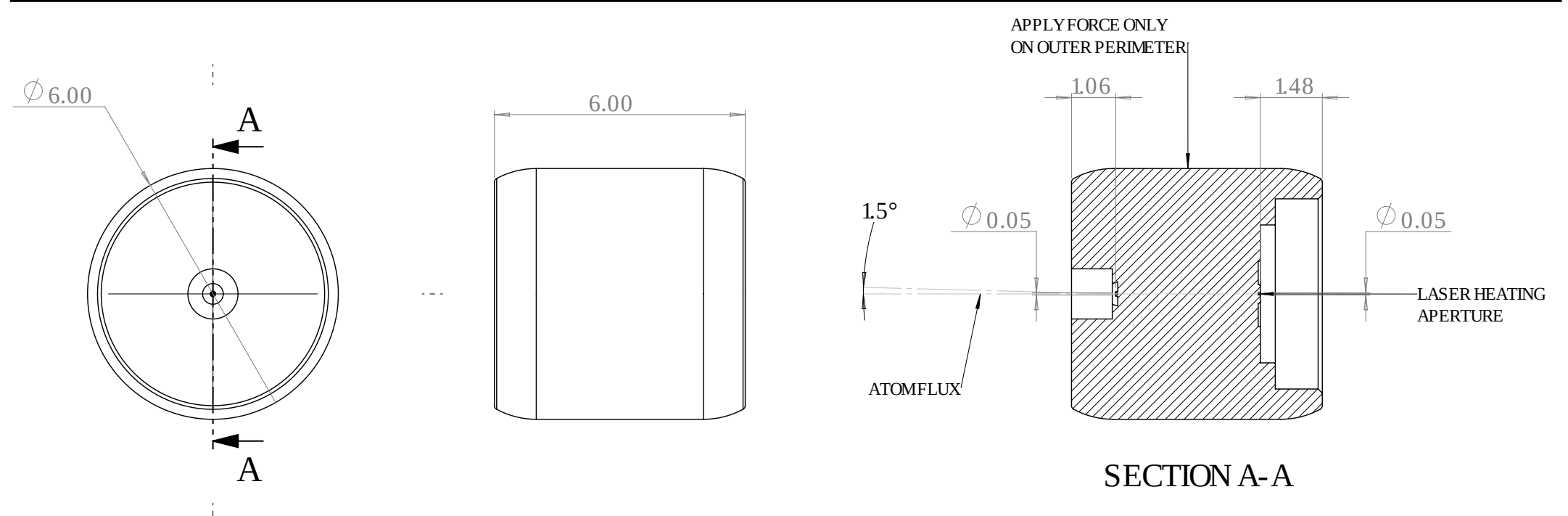

Request a Quote: [sales@quantumfabrix.com](mailto:sales@quantumfabrix.com)

